

A Novel Vlsi Architecture By Shift Based Accumulation In Sc-Fdma Mimo Detectors

S.Jayakumari¹, A.Anbarasan²

¹PG Student, VLSI Design, Department Of ECE, Surya Group Of Institutions, India

²Assistant Professor, Department Of ECE, Surya Group Of Institutions, India

Abstract: Multiple-input multiple-output (MIMO) single carrier frequency division multiple access (SC-FDMA), which combines the advantage of diversities with frequency domain equalizers (FDE), has drawn great attention recently. Due to invention of digital video broadcasting 16-QAM and 64-QAM schemes are most widely used in recent wireless systems. In this paper we introduce a novel low complexity multiple-input multiple-output (MIMO) detector tailored for single-carrier frequency division multiple access (SC-FDMA) systems, suitable for efficient hardware implementations. The proposed detector starts with an initial estimate of the transmitted signal based on a minimum mean square error (MMSE) detector. Then in order to improve the initial estimate rate less reliable symbols with more candidates in the constellation are soft decoded. Efficient high-throughput VLSI architecture is used to achieve superior performance compared to the conventional MMSE detectors. The performance of the proposed design is close to the existing maximum likelihood post-detection processing (ML-PDP) scheme, while resulting in a significantly lower complexity. The efficiency of MIMO over high order constellations are verified through MATLAB BER simulation and complexity reduction is proved with hardware synthesis results.

I. Introduction

Next Generation (4G) communication networks, also known as Dynamic Spectrum Access Networks (DSANs) as well as cognitive radio networks [1] will provide high bandwidth to mobile users via heterogeneous wireless architectures and dynamic spectrum access techniques.

The inefficient usage of the existing spectrum can be improved through opportunistic access to the licensed bands without interfering with the existing users. 4G networks, however, impose several research challenges due to the broad range of available spectrum as well as diverse Quality-of-Service(QoS)[3]requirements of applications [1]. In all suggestions for 4G, the CDMA spread spectrum radio technology used in 3G systems and IS-95 is abandoned and replaced by OFDM[2] and other frequency-domain equalization schemes.

This is combined with MIMO (Multiple In Multiple Out) [3], e.g., multiple antennas, dynamic channel allocation and scheduling's. The advantages of wireless communications are Wireless communication has changed the dynamics of the working environment and workforce mobility. Anywhere, anytime work, Enhance productivity, Remote area connectivity, On-demand, Entertainment bonanza, Emergency alerts. The applications of wireless technology Security systems, Television, Wi-Fi, and Computer interface devices.

The basic uplink transmission technique is single-carrier transmission with cyclic prefix to achieve uplink inter user orthogonality and to enable efficient frequency domain equalization at the receiver side. The transmitter and receiver structure for SCFDMA transmission is shown in Fig 1 an SCFDMA structure is identified by the insertion of DFT spreading and inverse discrete Fourier transform (IDFT) dispreading at the transmitter and receiver, respectively. From this implementation structure, SCFDMA is also known as DFT-spread (DFT-S) OFDM, which is a form of the single-carrier transmission technique where the signal is generated in the frequency domain.

The DFT spreading combines parallel M-PSK/M-QAM symbols to form an SCFDMA symbol. To formulate the DFT-S system, we can start by defining s_m as the m th transmitted symbol at the output of an equivalent OFDM system. The modulator converts the random bit stream input to the M-QAM/M-PSK symbols represented by the vector x_m of length N_d . The OFDM system then constructs s_m as

$$s_m = F_m \times x_m \quad (1)$$

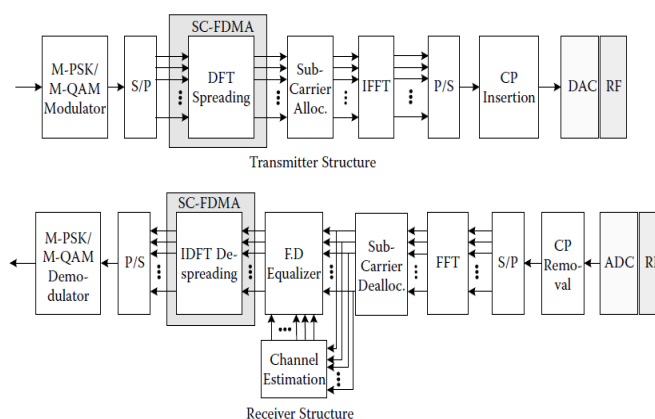

Fig. 1 SC FDMA and SC FDMA basic transmitter and receiver structures

II. Proposed Approach

A novel low-complexity MIMO detector tailored for SC-FDMA systems [3], suitable for efficient hardware implementations. The proposed detector starts with an initial estimate of the transmitted signal based on a MMSE detector. The objective is going to analyze the BER performance of shift based accumulation in MIMO detectors. The 3rd generation partnership project (3GPP) defined long term evolution (LTE) to meet the requirements of the 4G wireless communication. LTE combines multiple-input multiple-output (MIMO) technology with orthogonal frequency division-multiple access (OFDMA) technology [7] in the downlink and single carrier-frequency division multiple access (SC-FDMA) in the uplink to achieve peak data rates of 300Mbps and 75 Mbps, respectively. LTE-Advanced (LTE-A), which is an evolution of LTE, supports single-user spatial multiplexing of up to eight layers in the downlink and four layers in the uplink targeted to achieve peak data rates of 1 Gbps and 500 Mbps, respectively [2]. The SC-FDMA utilizes a discrete Fourier transform-spread OFDM (DFT-S-OFDM) modulation with similar performance compared to the OFDM. Its main advantage is to provide a lower peak-to-average power ratio (PAPR).

a) SC-FDMA MIMO Transmitter

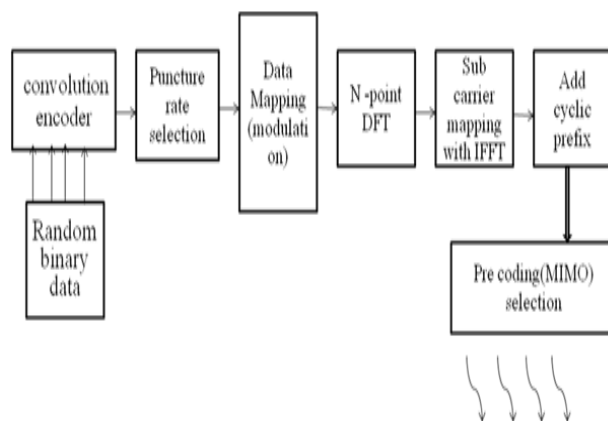

Fig. 2 Block diagram of SC-FDMA MIMO Transmitter

The MIMO SC FDMA system consists of no of transmit antenna and receive antenna for multiple users. The transmit antenna data streams are grouped into blocks and elements are chosen from Q-ary QAM constellation. Next we have to map the frequency domine outputs in DFT to orthogonal sub carriers using sub-carrier mapping. A random binary data is given as a input for convolution encoder. In convolution encoder the given data is encoded as 0s and 1s. In a puncture rate selector is used to select the required data for transmission. In modulation we use two techniques we commonly used:

1. Localized method
2. Distributed method

a) Localized method

In this localized method the outputs of each core occupy consecutive sub carriers in the bandwidth.

b) Distributed method

In this type of modulation method the outputs are spread over the Entire bandwidth with zeros on the unoccupied sub-carriers here the sub-carriers allocated to each user are consecutive in the LTE standard. So the resulting FD SC FDMA signal is transmitted into time domine through an IFFT [1] operation. Finally, a cyclic prefix is inserted and the final SC FDMA signal [5] is ready for transmission. A novel low-complexity MIMO detector tailored for SC-FDMA systems, suitable for efficient hardware implementations. For the selected symbols, extra possible candidates in the constellation are explored to see if they result in a better estimate. The selected symbols are, in fact, the ones that were initially more prone to error, called the “erroneous symbols.”

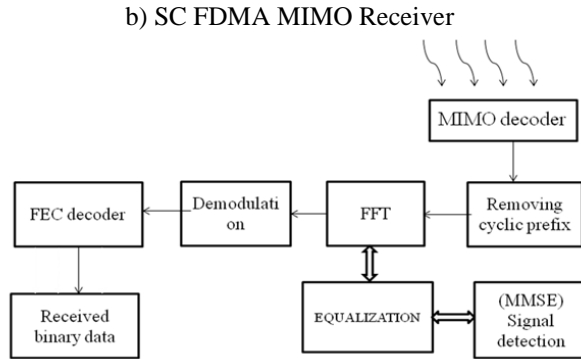

Fig .3 Block diagram of SC-FDMA MIMO Receiver

A conventional linear SC-FDMA detector for user is depicted. After the CP removal channel impulse response (CIR) between the transmit antenna and the receive antenna for user .Using an N-point fast Fourier transform (FFT) and performing the sub-carrier de-mapping, the FD signal of user, received at antenna oval on antenna at the C-FDMA receiver with receive antennae. So here the equalizer design is very challenging compared to normal MIMO OFDMA detection. ML detector is impossible in the frequency domine due to the blending effect of DFT. ML detection provides the best performance.

III. Algorithm Analysis

a) Hard decision detection algorithm

The PDP algorithm in this paper, consisting of three stages, is illustrated in Fig 4 where, is the channel matrix for the sub-carrier and the superscript is the Hermitian transform. These stages are described in the sequel.

First Stage: An MMSE equalizer1 is utilized to produce the initial estimate of the symbol sequence by reversing the channel effect for each sub-carrier to estimate the transmitted FD signals. Subsequently, an $-point$ IDFT operation is executed on all sub-carriers to find time-domain signals. Therefore, the effect of the channel and the DFT are taken into account independently in this stage of the detection process. The IDFT outputs (i.e.,) are then mapped to the constellation points and grouped to produce symbols in the initial estimate.

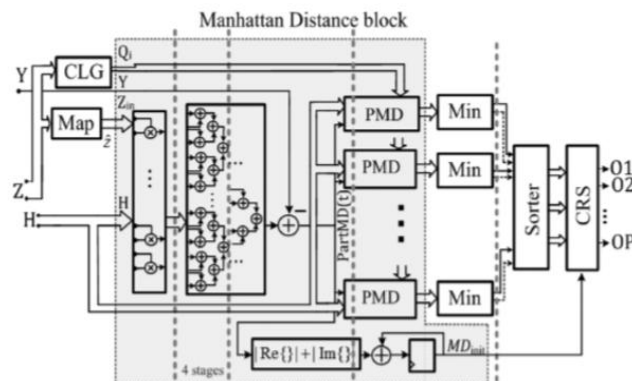

Fig .4The second and third stages of the proposed hard PDP architecture

Second Stage: In order to improve the initial MMSE estimate, a number of symbols in the initial estimate are selected. For the selected symbols, extra possible candidates in the constellation are explored to see if they result in a better estimate. The selected symbols are, in fact, the ones that were initially more prone to

error, called the “erroneous symbols.” In order to find the erroneous symbols, a liability metric (i.e., the error probability (EP) metric) is defined for each symbol representing its error probability. To calculate the EP metric, each symbol in the initial estimate is replaced with all other possible constellation points, with their corresponding Euclidean Distances(ED) calculated while other symbols remain unchanged.

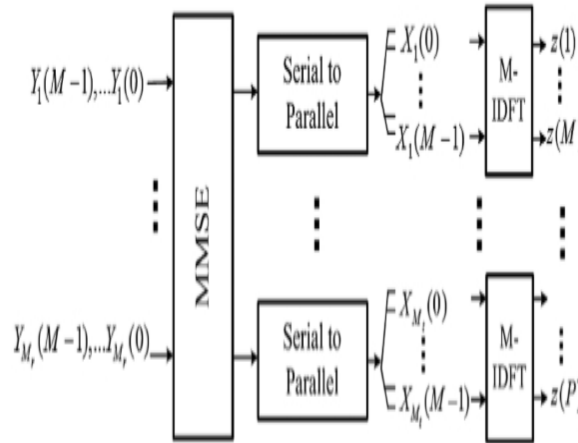

Fig.5 The first stage of the proposed architecture.

Stage1: Initial estimation of received symbols by channel reversing. To find frequency domain estimation through IDFT.IDFT outputs are mapped to produce initial estimate.

Stage2: Possible candidates in the constellation are explored. To compare it with initial estimate to find erroneous symbols. To carry out the error probability (EP) metric calculations. Initial estimate symbol is replaced with all other possible constellation points

Stage 3: For each erroneous symbol corresponding EDs are calculated while other symbols remain unaltered. To start iterative algorithm .only specified number of erroneous symbols is selected in each iteration for resource sharing

b) Soft detection algorithm

The architecture in Section VI provides a hard decision output (i.e.ZF) based on the transmitted symbols. While the proposed structure provides a superior BER performance compared to the conventional MMSE receivers, a soft-coded system is proposed that complies with advanced wireless standards. In a coded system, the transmitter encodes the message by using an error-correcting code. At the receiver, the decoding is performed based on the extrinsic log-likelihood ratios (LLR) calculated by the MIMO detector [5]. The LLRs are in fact the soft information representing the reliability of the detection. In contrast to a hard MIMO detector where a hard decision is made for each bit, a soft MIMO detector generates a value for each bit representing the probability of its being one or zero.

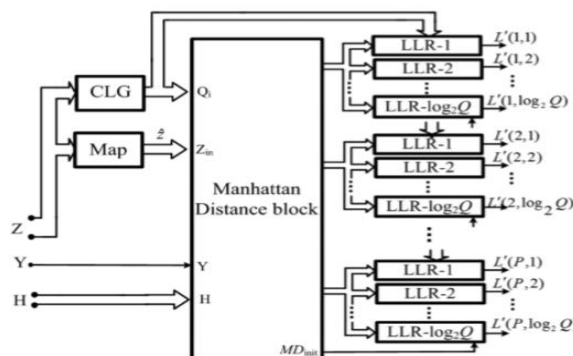

Fig.6 The second and third stage of the MMSE soft detection architecture.

Step1: log-likelihood ratios (LLR) calculated by the MIMO detector. Consider it as initial estimation

Step2: An ED calculation [4] of this initial estimation over stage 2 MMSE output is carried out. Instead of checking all the possible combinations, only the vectors, which are identical to the MMSE output to generate Manhattan distance block.

Step3: simplified LLRs are scaled before feeding these values to the decoder. These scaling factors which can be calculated in the MMSE detector in the first stage of the detection. The advantages of soft detection algorithms

- a) Equalizer complexity will be reduced by reducing no of multipliers.
- b) It causes reduced no of logical elements so area of the chip also reduced sufficiently.
- c) Number iteration will also be reduced for signal detection. This will increase decoding speed.

IV. Software Implementation Results

a) MIMO per analyzes over 4-QPSK

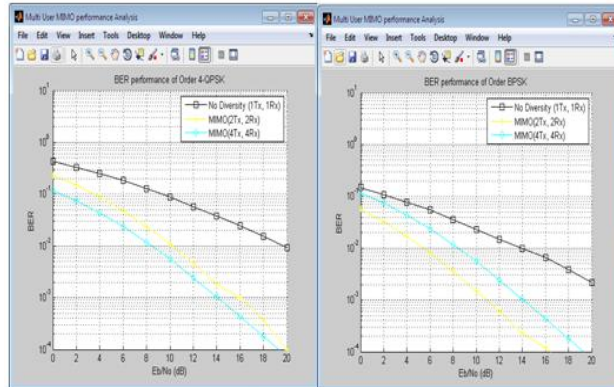

b) MIMO per analyzes over 64-QAM

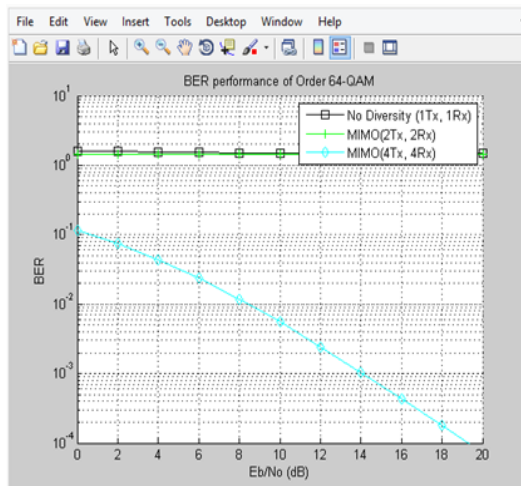

c) Performance of equalizers over multipath interference

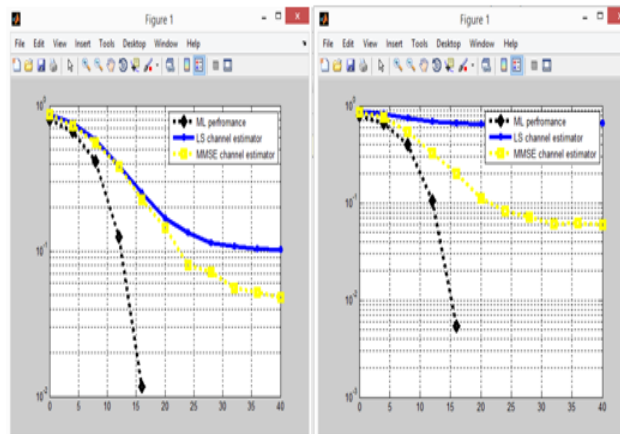

d) Modelsim output

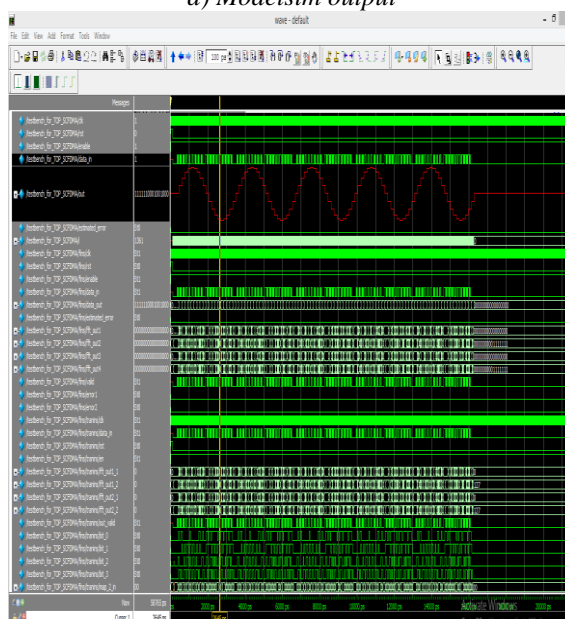

V. Table

Trade off analyzes of ML Vs MMSE with QUARTUS II hardware synthesis using CYCLONE III family (EP3C16F484C6)

Table 5.1

EQUALIZERTYPE	AREA	SPEED
ML	1487 with 112 MUL	67.74MHz (RX) 430.66MHz(TX)
MMSE	958 with 64 MUL	126.45MHz(RX) 427.9MHz(TX)
MMSE with SOFT decoding	1447 with 64 MUL	131.06MHz(RX) 483.09MHz(TX)

VI. Conclusion

In this paper, we analyze the performance of different equalization algorithm for SCFDMA system. Initially we analyzes the MIMO sytems and SCFDMA multiple access scheme with various ,modulation schemes over distance metrics .The proposed algorithm is based on channel estimation that exploits the sparsity of the estimated error signal. We also perform MMSE with soft decoding based symbol selection in each iteration to prove the fast convergence. We illustrated the performance of our algorithm in numerical simulations, and our algorithm shows a significant performance improvement compared to linear equalizers, while the BER rate is much lower compared to feeding back one symbol at a time for channel estimation.

The practical architecture of a practical receiver was implemented and tested for MIMO SC-FDMA systems resulting Superior BER Performance, Lower complexity, Large constellation sizes.

References

- [1]. C. P. Fan and C. H. Fang, "Efficient RC low-power bus encoding methods for crosstalk reduction," Integr. VLSI J., vol. 44, no. 1, pp. 75–86, Jan.
- [2]. S. Murali, C. Seiculescu, L. Benini, and G. De Micheli, "Synthesis of networks on chips for 3D systems on chips," in Proc. Asia South Pacific Design Autom. conf., Jan. 2009, pp. 242–247.
- [3]. E. Musoll, T. Lang, and J. Cortadella, "Working-zone encoding for reducing the energy in microprocessor address buses," IEEE Trans. Very Large Scale Integr. (VLSI) Syst., vol. 6, no. 4, pp. 568–572, Dec. 1998.

- [4]. M. Palesi, G. Ascia, F. Fazzino, and V. Catania, "Data encoding schemes in for networks on chip topology synthesis for 3-D systems on chips," in Proc.IEEE Trans.Comput.-Aided Design Integr. Circuits Syst., vol. 29, no.12, pp.1987- 2000, Dec. 2010
- [5]. C. Seiculescu, S. Murali, L. Benini, and G. De Micheli, "Sun Floor 3D:A tool optimization of application-specific systems," IEEE Trans. Very Large scal integr.(VLSI) Syst., vol. 9, no. 2, pp. 377–383, Apr. 2001.